



This document is from Humphrey's Technical Library. If you need technical or sales assistance, please contact a Humphrey distributor. To locate the Humphrey distributor closest to you, please dial 1-800-477-8707.

Title: 401/402 Solenoid Valves

ISO Date: October 31, 1997

Don't Take Chances

Compressed air is an extremely powerful medium. Always take maximum precautions when handling any component of a compressed air system. **Never** attempt to construct, replace, operate or service any component of a compressed air system unless you have been specifically and properly trained to do so. **Always** disconnect the supply air and exhaust the air system before attempting to remove or service a component of that system. Failure to heed these warnings could result in **SERIOUS, EVEN FATAL, PERSONAL INJURY.**

Design And Specifications

The design and specifications and other product information contained in this catalog is for general reference purposes based upon customary and usual manufacturing standards and product applications. However, it is difficult to predict or to anticipate the functioning or suitability of the product for any particular application or use. Therefore, nothing herein shall be deemed a representation or warranty of the product design or specifications and Buyer shall have the responsibility for investigating and testing the product in any particular application or use and all risks attendant in such use.

Humphrey Products Company
1-800-477-8707
Kalamazoo MI 49003
<http://www.humphreypc.com/air/>

Humphrey 401/402 Micro Solenoid Valves

Humphrey introduces the first 10 millimeter-wide micro solenoid air valves designed and manufactured in the United States.

The new 400 Series direct acting micro solenoid valves feature small size, light weight, and a poppet design field proven by years of reliable service in thousands of tough applications worldwide.

Other attributes of these single or double solenoid valves are low AC or DC power consumption, electrical plug connectors, surge suppression circuit, indicator light, and manual override. They can be mounted directly in the media supply line or on two different subbases or two styles of manifolds.

Humphrey's 400 Series valves meet the challenges of new technology's demanding pneumatic control applications.

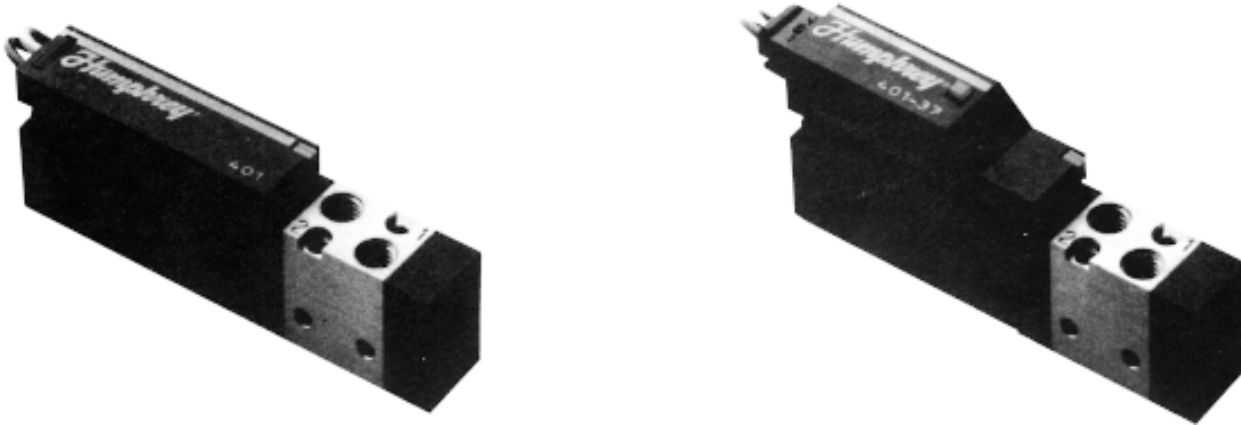

401

Model 401 is a 4 way, 5 port, 2 position, spring return valve. Direct acting, with a single solenoid and 12 inch lead wires exiting the solenoid cover via rubber grommet. Continuous duty coil. Non-locking

manual override. 10-32 threaded IN and Delivery ports. Exhaust ports not threaded. Use in-line or with manifold (MO/MO-70) mounting.



401-37

Model 401-37 is identical to 401. Electrical connector features 12 inch leads pre-wired to custom electrical plug connector which

attaches to circuit board within solenoid cover. Integral red LED indicator light illuminates when power is applied to the valve.

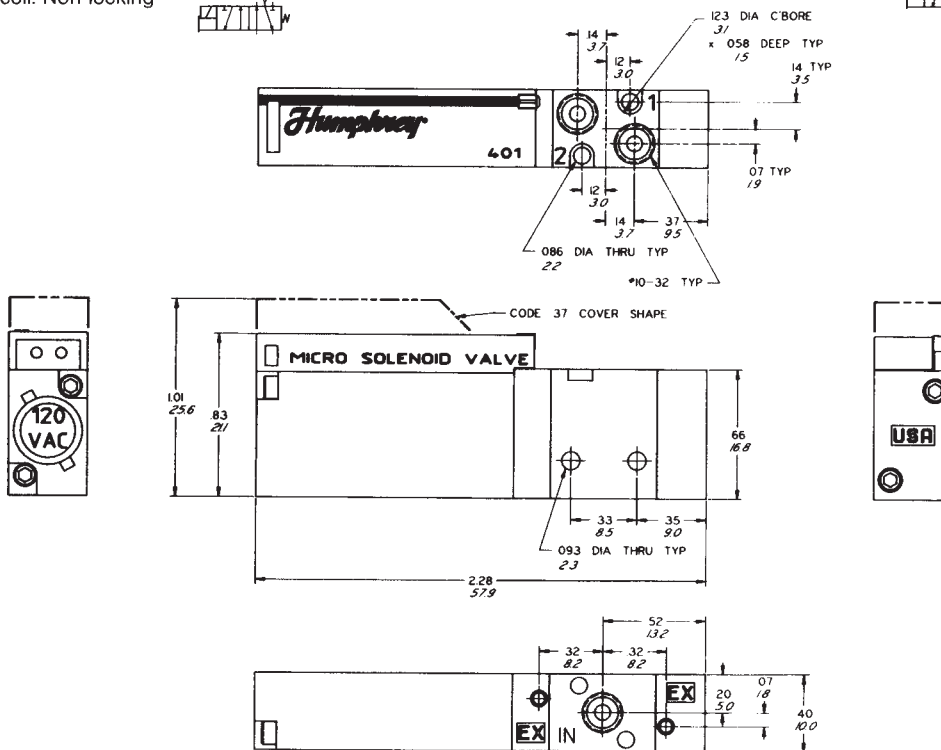

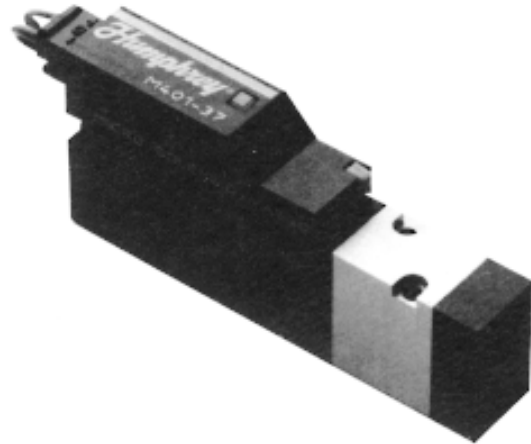
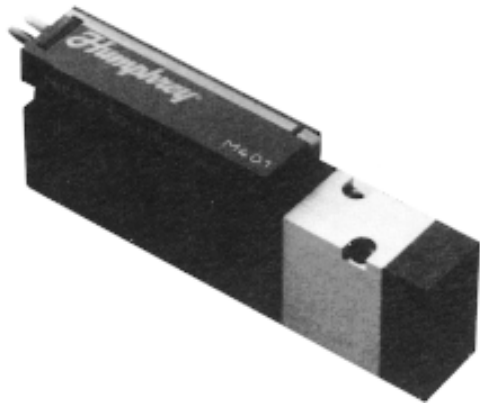

M401

Model M401 is similar to 401.
Use with subbase (SO1/SO1-70)
or with manifold (MO/MO-70)
mounting.



M401-37

Model M401-37 is similar to
401-37. Use with subbase
(SO1/SO1-70) or with manifold
(MO/MO-70) mounting.



Specifications

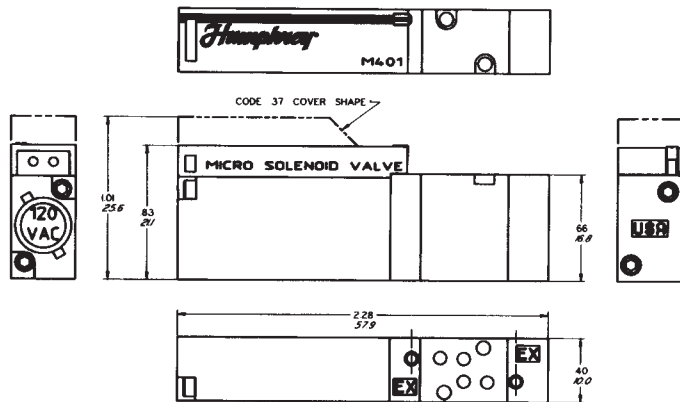

401/402 Air Flow To Atmosphere

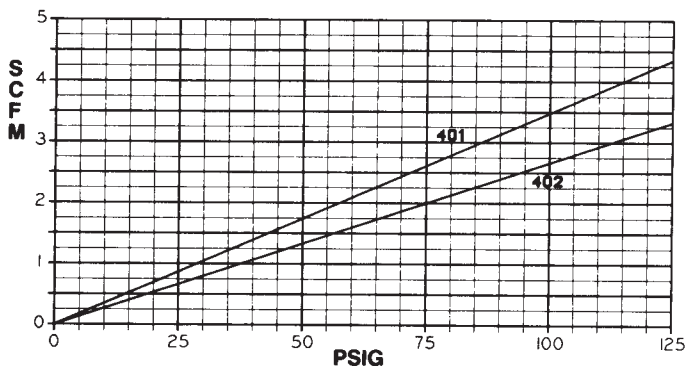

	401 Models
Media	Air, Vacuum, or Inert Gases
Pressure Range	28" Hg. Vacuum to 125 PSIG (8.5 bar)
Ambient Temperature Range	32 to 125°F (0 to 52°C)
Temperature Rise	90°F (35°C)
(Any Voltage)	
SCFM @ 100 PSIG (7.0 bar)	3.5
Cv	.05
Fill/Exhaust @ 100 PSIG (7.0 bar)	
1 cu. in.	.06/10 sec.
10 cu. in.	.60/1.0 sec.
100 cu. in.	6.0/10.0 sec.
Leak Rate (Max. allowed)	4 cubic centimeters/minute @ 100 PSIG (7.0 bar)
Type of Operation	Direct Solenoid
Effective Area	.003 square inches (1.98mm ²)
Stroke	.018 inches (.46mm)
Power Consumption (AC/DC)	2 Watts
Response Time (On/Off)	.010/.005 sec.
Maximum Cycle Rate	2400 DC (Grommet)
(Cycles/Min.)	1200 AC (Code 37)
	1200 AC
Voltage Tolerance	± 10% of Rated Voltage
Lubrication	Not Required
Filtration	40 Micron Recommended
Weight	1.12 oz. (32g.)
Materials	Aluminum, Stainless Steel, Buna, Plastic, Steel, Brass, Urethane
Lead Wire	PVC Insulated hook up wire
	UL 1007, CSA TR-64
	300 Volts, 80°C
	24 AWG - 7/32 Stranding

Humphrey Micro Valves — Double Solenoid

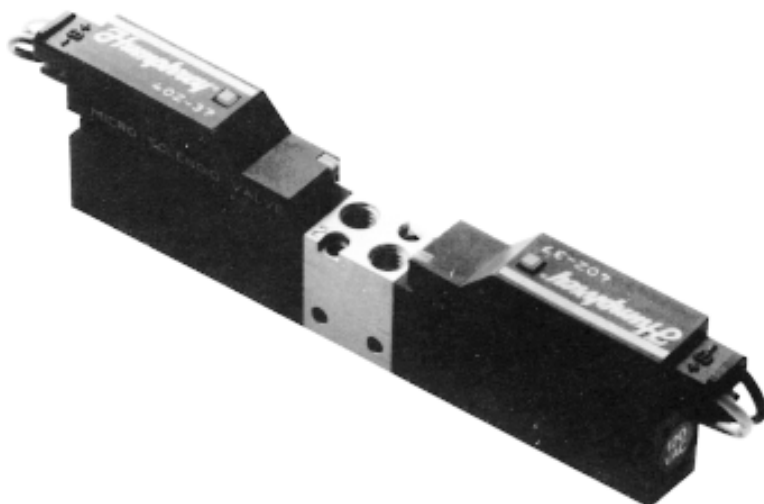
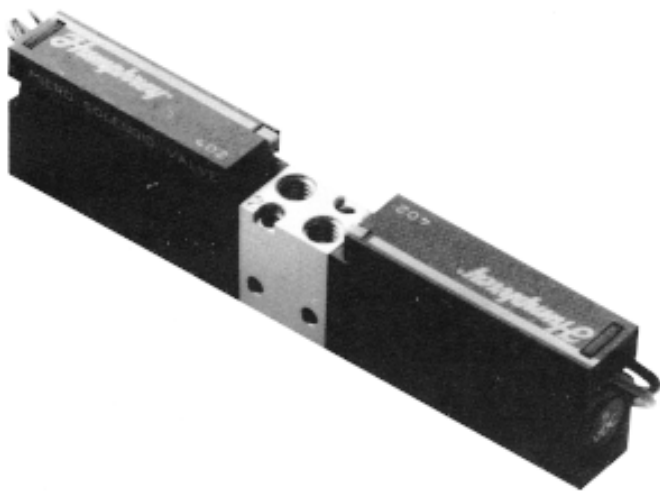

402
Model 402 is a 4 way, 5 port, 2 position detented valve. Direct acting, with a double solenoid and 12 inch lead wires exiting solenoid covers via rubber grommet. Continuous duty coil. Dual non-locking

manual override. 10-32 threaded IN and Delivery ports. Exhaust ports not threaded. Use inline or with manifold (MO/MO-70) mounting.



402-37
Model 402-37 is similar to 402. Electrical connector features 12 inch leads pre-wired to custom electrical plug connector which

attaches to circuit board within solenoid cover. Integral red LED indicator light illuminates when power is applied to the valve.

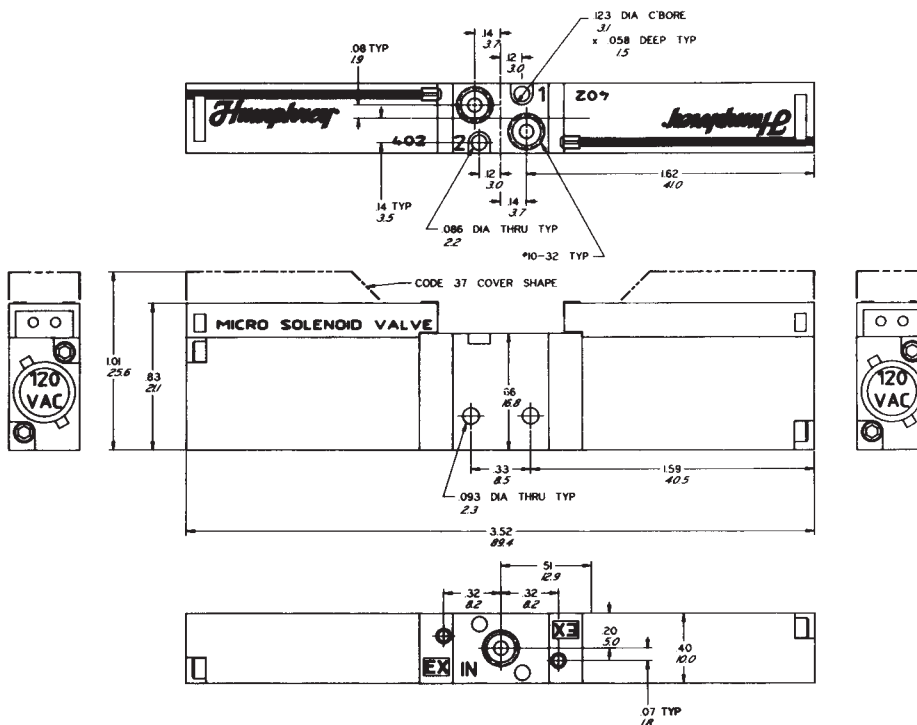

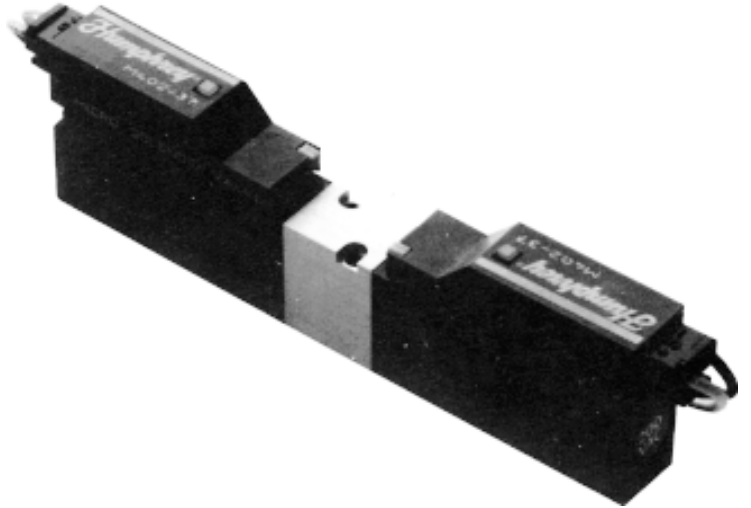
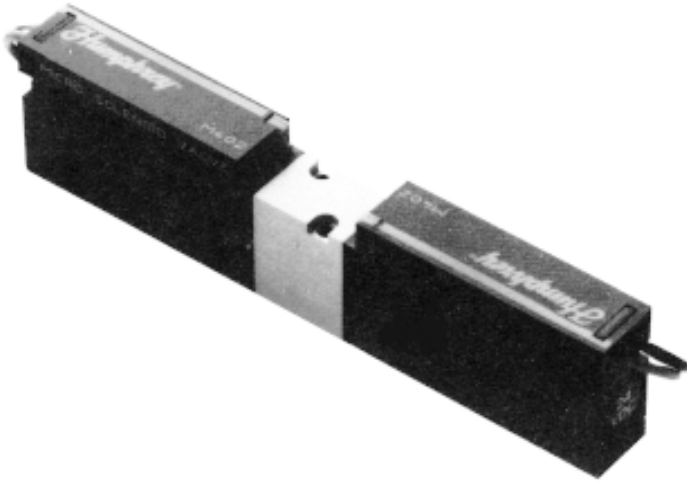

M402

Model M402 is similar to 402.
Use with subbase (SO1/SO1-70) or
with manifold (MOC/MOC-70) mounting

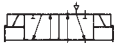

M402-37

Model M402-37 is similar to
402-37. Use with subbase
(SO1/SO1-70) or with manifold
(MOC/MOC-70) mounting.



Specifications

402 Models

Media	Air or Inert Gases
Pressure Range	30 to 125 PSIG (2 to 8.5 bar)
Ambient Temperature Range	32 to 125°F (0 to 52°C)
Temperature Rise (Any Voltage)	90°F (35°C)
SCFM @ 100 PSIG (7.0 bar)	2.7
C _v	.04
Fill/Exhaust @ 100 PSIG (7.0 bar)	
1 cu. in.	.07/.11 sec.
10 cu. in.	.70/1.1 sec.
100 cu. in.	7.0/11.0 sec.
Leak Rate (Max. allowed)	4 cubic centimeters/minute @ 100 PSIG (7.0 bar)
Type of Operation	Direct Solenoid
Effective Area	.003 square inches (1.98mm ²)
Stroke	.018 inches (.46mm)
Power Consumption (AC/DC)	2 Watts
Response Time (On/Off)	.010/.010 sec.
Maximum Cycle Rate (Cycles/Min.)	2400 DC, AC
Voltage Tolerance	± 10% of Rated Voltage
Lubrication	Not Required
Filtration	40 Micron Recommended
Weight	1.92 oz. (54g.)
Materials	Aluminum, Stainless Steel, Buna, Plastic, Steel, Brass, Urethane
Lead Wire	PVC Insulated hook up wire UL 1007, CSA TR-64 300 Volts, 80°C 24 AWG - 7/32 Stranding

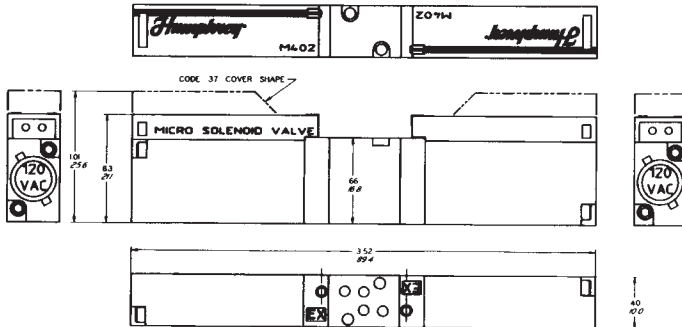

Humphrey MO Manifolds — MOC Manifolds



MO MANIFOLDS

MO manifolds accept any combination of 401 or 402 valves using valve's delivery ports as cylinder outlet ports. This simplifies plumbing and increases inventory flexibility. Made of one piece anodized aluminum and available in 2-16 stations, these manifolds have a

common inlet and common captured exhaust. Manifold has no cylinder outlet ports. Valve delivery ports (1 & 2) are cylinder outlet ports. Mounting screws and gasket furnished for each manifold station. Available with optional Code 70 flow controls at each station.

MOC MANIFOLDS

MOC manifolds accept any combination of M401 or M402 manifold valves. Integral cylinder outlet ports (2 per station) permit valve installation or removal without disconnecting any plumbing. Made of one piece anodized aluminum and available in 2-16 stations, these

manifolds have a common inlet and common captured exhaust. Manifolds have integral cylinder outlet ports (2 per station). Mounting screws and gasket furnished for each manifold station. Available with optional Code 70 flow controls at each station.

MO Manifold Gasket Configuration



Gasket #43-262

Manifold with Code 70 option shown. Same dimensions for MO Manifolds (no Code 70 flow controls).

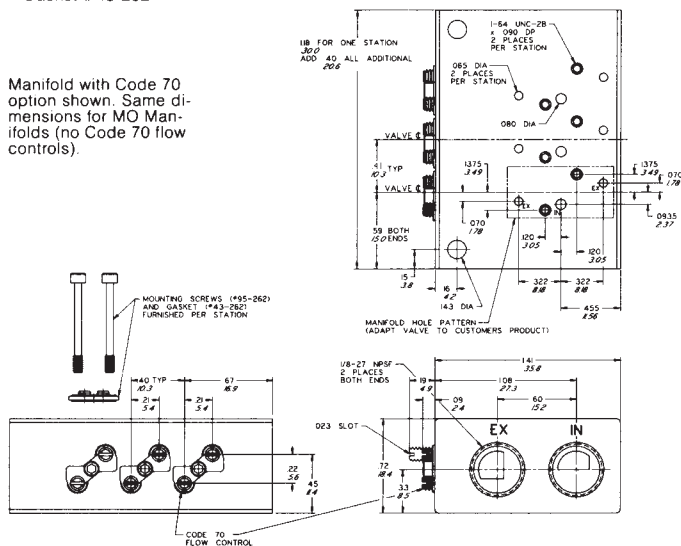

MOC Manifold Gasket Configuration



Gasket #43-261

Manifold with Code 70 option shown. Same dimensions for MOC Manifolds (no Code 70 flow controls).

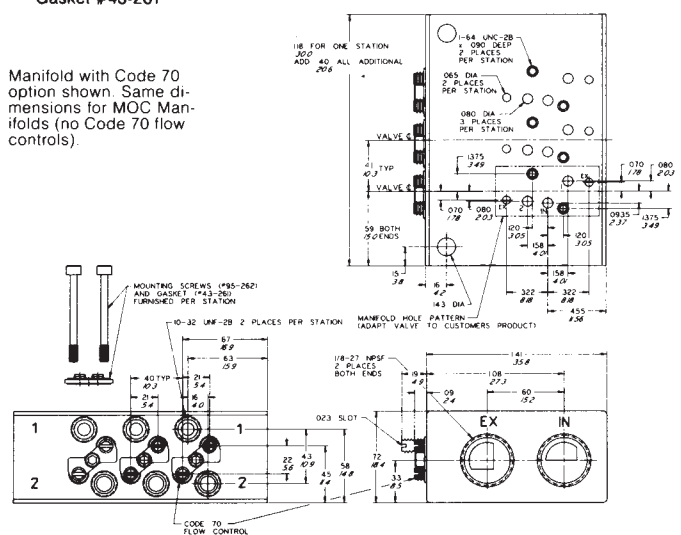

Humphrey Block-off Plate — Valve Manifold Assemblies

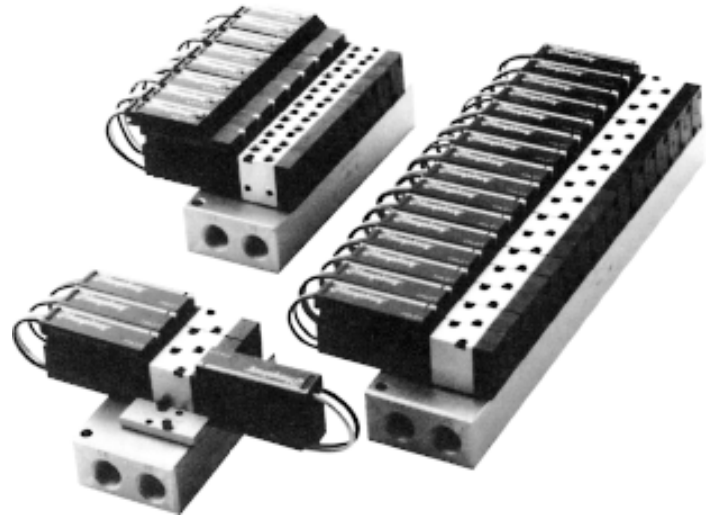
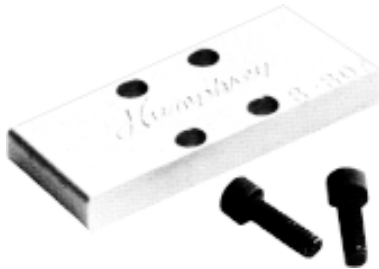

401, 402, 8-80A
on MO3-70 Manifold

BLOCK-OFF PLATE

Model 8-80A anodized aluminum block-off plate is used to suspend use of any station on any MO or MOC manifold. It is frequently used to permit future valve additions as

related to machine option. Mounting screws furnished; use gasket furnished with manifold station. Weight: 0.07 oz. (2 gms.)

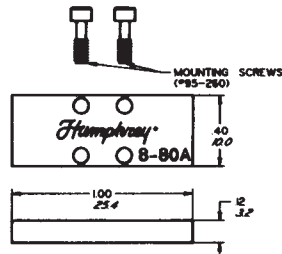

VALVE MANIFOLD ASSEMBLIES

NOTE: Some fittings may protrude beyond valve body side requiring use of washers or shim stock to space valve away from non-manifold mounting surfaces.

401, 402, 8-80A
on MO3-70 Manifold

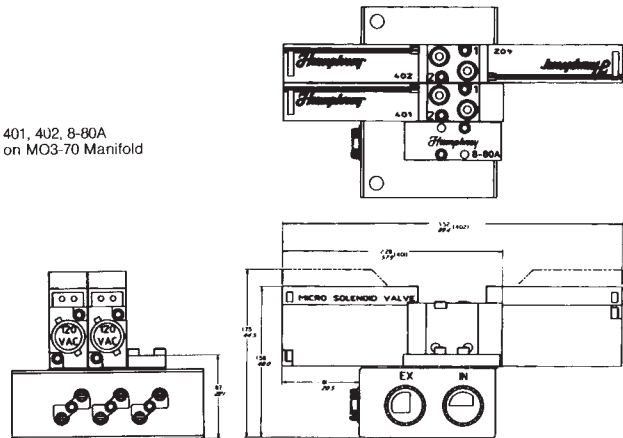

M401, M402, 8-80A
on MOC3-70 Manifold

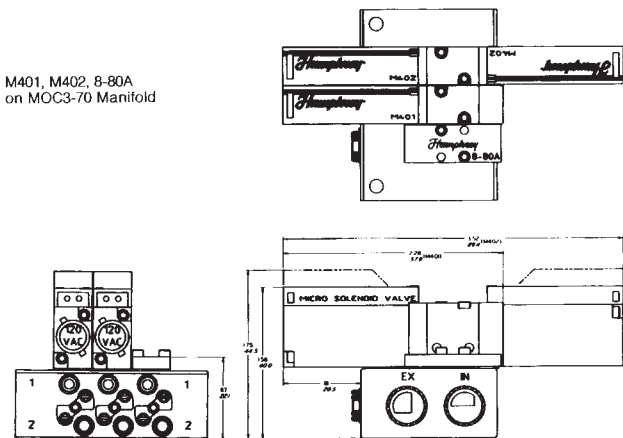

Valve Manifold Assemblies

Manifold mounting permits convenient sub-assembly of control valves and other components for installation as a complete pneumatic control unit for the user's product. This procedure saves labor and expense by eliminating individual valve and flow control installation or service of single or multiple valves without disrupting plumbing. Manifold mounting frequently saves space and simplifies plumbing.

Humphrey's manifolds offer the added advantage of accepting combinations of both single and double solenoid valves.

The 8-80A block-off plate can be installed on any station of either manifold.

Humphrey SO1-SO1-70 Subbase — Valve Subbase Assemblies



SO1 SUBBASE

SO1 subbase permits independent mounting of any M401, M401-37, M402, or M402-37 valve. Provides any alternative to mounting valve individually with body mounting holes. Provides a permanent

plumbing device and facilitates changing valves. Permits captured exhaust of single valve units. Mounting screws and gasket furnished. Weight: 0.6 oz. (17 gms.)



SO1-70 SUBBASE

SO1-70 subbase provides the same features as SO1 subbase with the addition of Code 70 flow controls.

Saves space, streamlines plumbing and reduces cost.

Subbase with Code 70 option shown. Same dimensions for SO1 Subbase (no Code 70 flow controls).

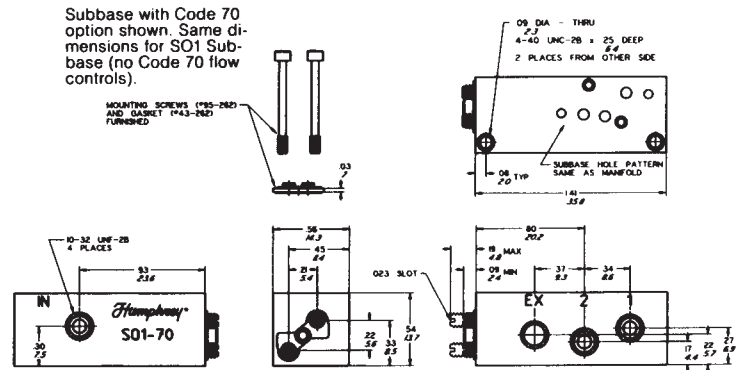

VALVE SUBBASE ASSEMBLIES

Subbase mounting provides the convenience of manifold mounting for single valve units and offers an alternative to mounting valves individually with body mounting holes. Subbases provide a permanent plumbing device which enables valves to be changed quickly

without disturbing plumbing. They are also capable of capturing exhaust and can be ordered with Code 70 flow controls.

Subbases accept either single or double solenoid valves as well as the 8-80A block-off plate.

NOTE: Some fitting may protrude beyond valve body side requiring use of washers or shim stock to space valve away from non-manifold mounting surfaces.

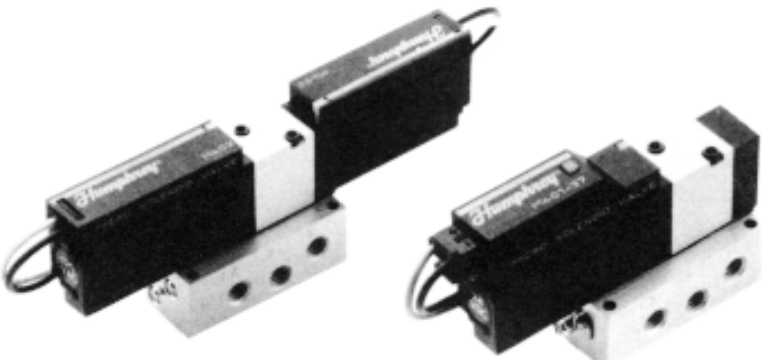

M401 on SO1-70 Subbase

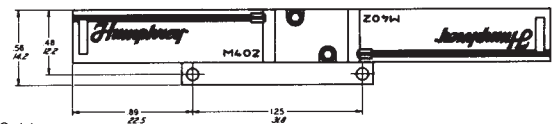
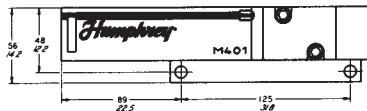

M402 on SO1-70 Subbase

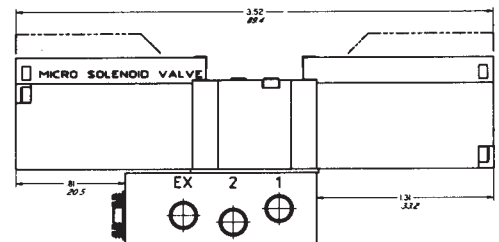
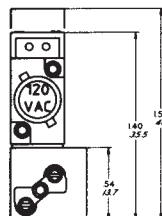
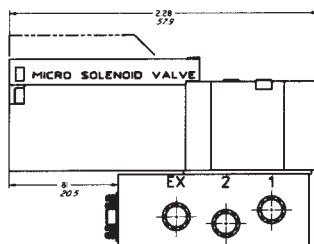
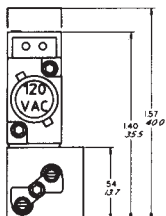

FLOW RATES/C_v

Humphrey recommends "fill/exhaust times," which are related to various chamber sizes, as the best method for calculating total valve and device (specifically, cylinder) response time. Humphrey recognizes the industry's use of flow coefficient C_v as a comparison standard.

Consequently, Humphrey offers three types of flow data. The National Fluid Power Association's standards for C_v, the SCFM flow rate determined by flowing to atmosphere, and Humphrey's preferred "fill/exhaust times."

Model	C _v	SCFM @ 100 PSIG	Fill Time (Sec)			Exhaust Time (Sec)		
			(0 to 90 PSIG)	(0 to 100 PSIG)	(100 to 10 PSIG)	(100 to 10 PSIG)	(100 to 10 PSIG)	(100 to 10 PSIG)
			1	10	100	1	10	100
401	0.05	3.5	.06	.60	6.0	.10	1.0	10.0
402	0.04	2.7	.07	.70	7.0	.11	1.1	11.0

Note: Manifolds cause some reduction of flow rates.

Example of how to calculate fill/exhaust times:

Model 401, 24VDC Two Air Lines (0.125 I.D. x 36-inch long)
 100 PSIG supply Air Cylinder (1.062-inch bore x 4-inch stroke)
 Volume = 0.785 x Diameter squared x stroke or length

Cylinder Volume	= 3.54 cubic inches
Air Line Volume	= 0.44 cubic inches
Total Circuit Volume	= 3.98 or 4 cubic inches

T1 Time to Energize Valve	= 0.010 sec.
Time to Fill 4 cubic inches	= 0.240 sec.
= 40% of 0.6 sec. for 10 cubic inches	= 0.240 sec.
T3 Time to De-energize Valve	= 0.005 sec.
Time to Exhaust 4 cubic inches	= 0.400 sec.
= 40% of 1 sec. for 10 cubic inches	= 0.400 sec.
Total Cycle Time	= 0.655 sec.*

*Although this result is not exact, it is sufficient for most application needs and provides a simple, straightforward system.

RESPONSE TIMES

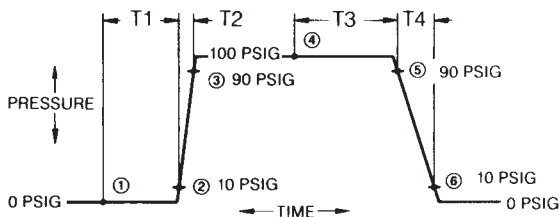

Identification of response time areas:

- T1 times are measured from point [1] (valve energization) to point [2] (10% of supply pressure detected at valve outlet port).
- T2 times are measured from point [2] (valve energized) to point [3] (90% of supply pressure).
- T3 times are measured from point [4] (valve de-energization) to point [5] (10% of supply pressure exhausted from outlet port).
- T4 times are measured from point [5] (valve de-energized) to point [6] (90% of supply pressure exhausted).

AC/DC Voltages

Model	T1	T2	T3	T3*	T4
401	.010 sec.	.002 sec.	.005 sec.	.014 sec.	.005 sec.
402†	.010 sec.	.002 sec.	.010 sec.	—	.002 sec.

*DC coils with suppression diode and AC coils. Measured at 70°F (21°C) with 100% voltage and 100 PSIG supply. Times shown are median performance of valves tested.

†When de-energized, double solenoid models rely upon pressure to maintain position. Therefore, they may require longer electrical signal duration when used with larger bore cylinders, to permit pressure/flow conditions to stabilize. Transient pressure surges may cause valve shift or leak. Exercise care in selecting valve for specific application.

SOLENOID CIRCUIT SCHEMATICS

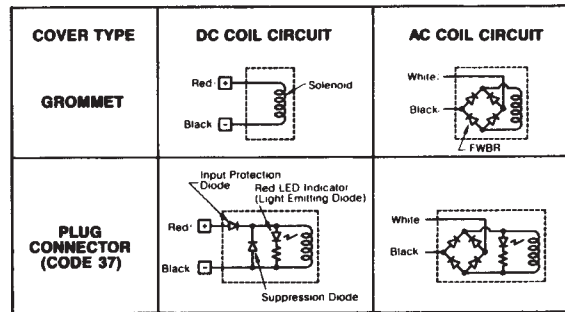

Cautions:

- Valves with plug connector (Code 37) and DC coils incorporate polarity protection. Improper voltage polarity prohibits valve operation; although no damage will result.
- Both solenoids of double solenoid type valves (402/M402) should not be energized simultaneously. Energizing both coils results in valve assuming an unpredictable position.
- External drive circuitry resulting in solenoid current leakages of greater than three milliamps (AC or DC) may cause improper valve operation.
- Ensure proper voltage supply per voltage label, ± 10% for AC or DC voltages.

ELECTRICAL SPECIFICATION CHART

All coils are continuous duty and conform to Class B insulation system (266°F/130°C). AC coils rated for 50/60 Hz.

Voltage	Cover Type*		Resistance (Ohms)	Current (Milliamperes)
	Grommet	Code 37		
5VDC	•	•	12.5	400
5VDC	•	•	8.7	485
12VDC	•	•	72.0	170
12VDC	•	•	63.0	180
24VDC	•	•	288.0	85
24VDC	•	•	270.0	90
24VAC	•	•	241.0	95
100VAC	•	•	4,660.0	22
120VAC	•	•	6,750.0	20
200VAC	•	•	18,970.0	11
240VAC	•	•	27,370.0	10

*Grommet - DC has coil only. AC has coil and full wave bridge rectification.

Code 37 - DC has coil, LED, input protection and suppression diodes. AC has coil, LED and full wave bridge rectification.

Resistance and Current are nominal values.

Valve assemblies (coils, circuits, connectors, etc.) are "Hi-Pot" tested to 1,750 VAC for 1 second.

CIRCUIT BOARD COMPONENTS

Drawing shows components incorporated into miniature circuit board used with plug connector type cover (Code 37). Circuit board is not used with grommet type cover except for AC voltages which incorporate full wave bridge diodes. Therefore, suppression and input protection diodes are furnished with Code 37 only.

Suppression diode protects other electronic components from valve's solenoid generated voltage transients ("noise").

Input protection diode prevents circuit (suppression diode/LED) damage in event of improper voltage polarity connection.

Modifications to electrical components and circuitry may be accomplished (space permitting) to satisfy a customer's unique requirements.

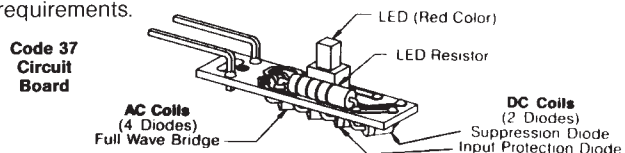

401/402 Micro Solenoid Series
#10-32 ports, 4-way, Direct operating

VALVES

	Electrical Plug Connector	Specify Voltage
Option Code	37	See Below
Model 401	SP	SP
M401	SP	SP
402	SP	SP
M402	SP	SP

Available Voltages

5VDC
 12VDC
 24VDC
 100VAC
 120VAC
 200VAC
 240VAC

MANIFOLDS

	Flow Controls	Description
Option Code	70	
MO	SP	2-16 station, anodized aluminum manifold without cylinder ports. Includes mounting screws and gasket.
MOC	SP	2-16 station, anodized aluminum manifold with cylinder ports. Includes mounting screws and gasket.

SUBBASES & ACCESSORIES

Model	Description
SO1	Subbase Assembly
	1-258 Subbase
	43-261 Gasket
	95-262 Screws (2 req'd)
	33-260 Ball (2 req'd)
8-80A	Block Off Plate Assembly
	8-80 Block Off Plate
	43-262 Gasket
	95-260 Screws (2 req'd)
SO1-70	Subbase Assembly With Flow Controls
	30-260 Retainer
	90-33 O-Ring (2 req'd)
	97-260 Adjusting Screws (2 req'd)
PL1A	DC Plug Connector Assembly
PL1B	AC Plug Connector Assembly
28-260A	Contacts (Box of 10)*
25-260	Connector
151-11	1/16" Hex Drive Tool
151-20	Humphrey Handy Wrench

*Order by quantity of boxes only.

HOW TO ORDER

Starting with Model Number specify options in order from left to right.

Example: To Order Model 401-37 12VDC

4-Way Operation, Single solenoid (401)
 Electrical Plug Connector (401-37)
 Voltage 12VDC (401-37 12VDC)

Remember: Option Codes marked STD and NA are not used as part of the Model Number when ordering. N/C indicates no charge but Option Code must be included in the Model Number. OS indicates that Option must be ordered separately and is not used as part of the Model Number.

N/C=No charge
 NA =Not available
 OS =Order separately, additional charge for this option

STD=Standard
 SP=Specify, additional charge for this option